



A PRODUCT OF AUTOMATED PACKAGING SYSTEMS

The Autobag Maximizer continuous-motion conveyor—Maximizes your investment by increasing your hand load productivity.

Capable of conveying and counting hand-placed items at speeds up to 70 batches per minute, this continuous motion, flighted conveyor has been designed to be simple to use, dependable and operationally flexible to double the productivity of hand load applications.

When used in conjunction with the Autobag AB 180 bagging system, a bulk supply of product is placed on the product load tray, an operator will then retrieve the required product for each pack and place it into one of the Maximizer flights. The conveyor drives the product to a field eye detection load area where the conveyor dispenses the product through the eye and into an accumulator funnel. The individual batch of product is then funneled to a pre-opened bag at which time the bag is sealed and dispensed while another bag is presented for loading.

Utilizing the very latest technology, the Autobag Maximizer is capable of detecting and counting product from 1/4" to 5.5" in length and up to 3" in width.

BPM

20

30

40

50

60

70

80

00095687 007

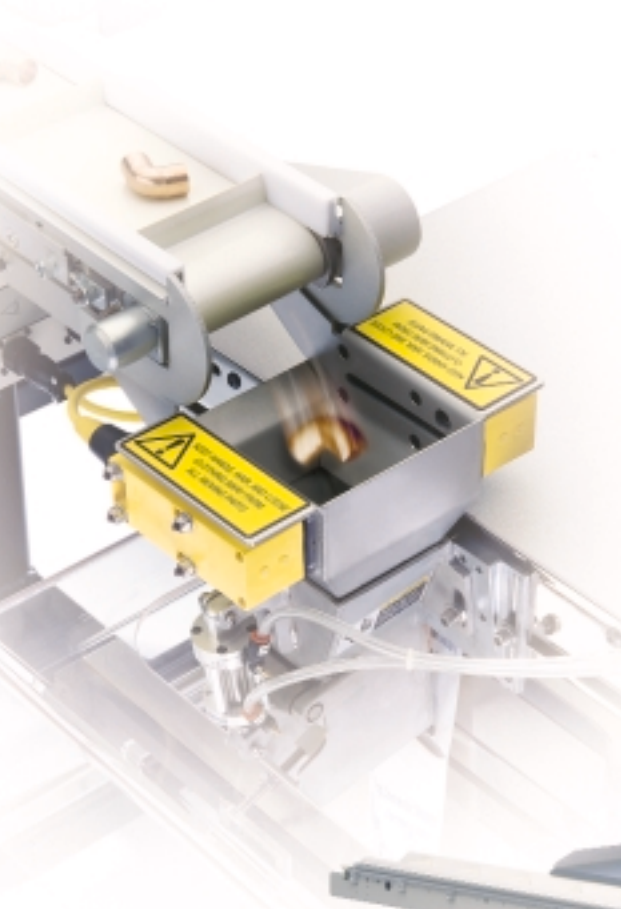

User Benefits

- Reduces labor cost while doubling packaging throughput, providing higher packaging productivity with fewer operators
- Ideal system for hand load kit packages and sub assemblies, giving the operator the time and control of the system speed rates
- Simple Eye Detection system allows changeover from product to product to be instantaneous
- Can be integrated with simple robotics providing integrated, efficient packaging of at-site assembled product
- Quick to set-up, easy to operate, reliable and fast



Standard Features

- Combines with Autobag bagging and printing systems to provide integrated, efficient in-line packaging
- 3.75" x 5.75" flighted compartments facilitating a wide range of products for flexibility
- Cantilevered frame for easy pivoting and adjustment
- Adjustable stainless steel load shelf for ease of operation
- Easy multiple adjustments allow you to set height, angle, and speed mode to meet a wide range of infeed requirements
- Adjustable belt speed control conveys up to 60 bags per minute as a product take-away conveyor
- Anti-jamming overload protection
- Electronic Eye Counter and Accumulator signals bagger to cycle only when Maximizer flight contains product, preventing empty bags in process

Options

- Side-feed or front-feed configuration
- Range of infeed funnels
- Remote mounting kit for AB 180 AutoTouch™ Control Screen
- Spare parts kits

Technical Specifications

Weight: 200 lb (90 kg)

Dimensions (with AB 180 bagger):

Max. Belt/Flight Load: 50 lb. (23 kg)

Electrical: 110/220 VAC; 50/60 Hz

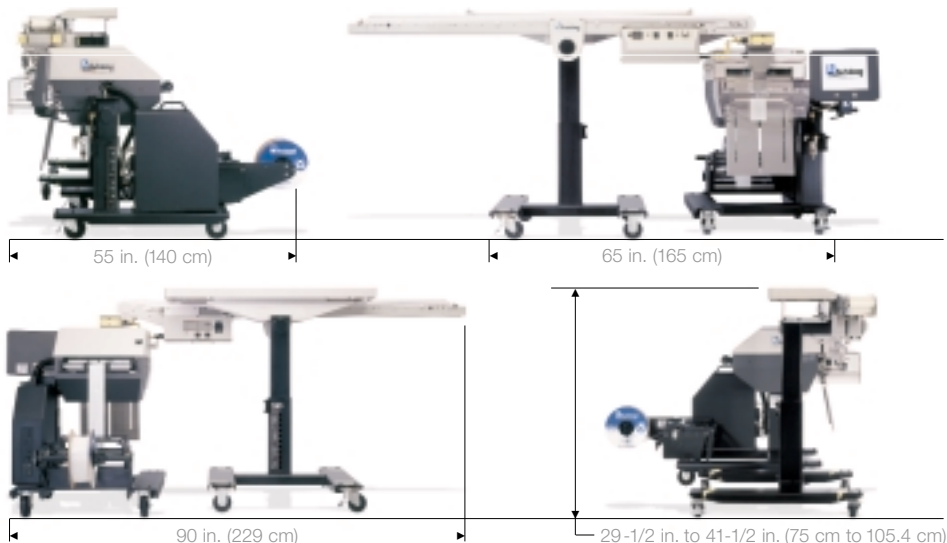

Typical Applications

- Automotive & appliance parts
- Hardware & DIY
- Electrical & electronic
- Fasteners & connectors
- Plumbing & heating
- Hobby & craft
- Jewellery & novelty items
- Cosmetics & beauty aids
- Disposable health care



In-Line Integrated Packaging

is achieved by combining the Maximizer and AB 180 bagger with the PI 412c imprinter. Autobag manufactures a complete line of infeed and imprinting equipment.

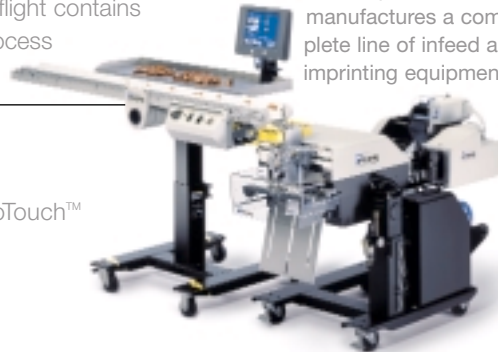

Mechanical Features

AutoTouch Control Screen from AB 180 bagging machine with decentralized mounting to Maximizer for easy operator access.



Flighted conveyor belt ensures part separation while accurately and efficiently moving product to counting eye.



Simple interface panel houses controls for setting single count or multi-batch, as well as continuous and intermittent indexing.



Automated Packaging Systems Inc.
10175 Philipp Parkway
Streetsboro, Ohio 44241
Tel: 888-288-6224
Fax: 330-342-2400

m a c h i n e s

m a t e r i a l s

s e r v i c e

s y s t e m s a d v a n t a g e